



# PVC TRUE UNION UTILITY BALL VALVES

TUU-2-0114

## Superior Quality, Full Featured, Multi-Purpose Ball Valve



Engineered for high performance and long life, Multi-purpose, full-featured PVC True Union Utility Ball Valves provide excellent 1/4-turn shutoff for the most demanding applications.

- PVC Chemical & Corrosion Resistant Construction
  - Replaceable HDPE/PTFE Seats
  - Self Adjusting Floating Seat design
  - EPDM or FKM O-ring Seals
  - Safe-T-Shear® Stem
  - Safe-T-Blocked v™ Seal Carrier
  - Impact Resistant Blue Polypropylene Handle
  - PN16 -Pressure rated to 232 psi @ 73° F (22° C)
  - Produced in ASTM IPS sizes 1/2" - 4" with Socket or NPT Threaded End Connectors (DIN, JIS Sockets and BSP Threads - available upon request)
  - All Valves Manufactured from NSF-61 Approved Material
- 
- **Convenient Double Union Design (True Union)**  
Double union design with strong Buttress thread union nuts allows easy servicing and replacement.
  - **Corrosion Resistant PVC Construction**  
All PVC construction provides optimum corrosion resistance. Never rusts, scales or pits.
  - **HDPE/PTFE or PTFE Floating Seats**  
Special processing provides the durability of standard High Density Polyethylene (HDPE) with the improved lubricity of PTFE for smoother operation or optional PTFE seats. Special "floating seat" design allows the seat to expand on closing and contract on opening. This maintains ball-to-seat contact, assuring proper adjustment and continual sealing.
  - **High Grade EPDM or FKM O-ring Seals**  
Only high grade EPDM or FKM seals are used.
  - **Full PN16 Service Pressure Ratings**  
Valves are rated to 232 psi (16 BAR) service pressure at 73° F (22° C). Maximum service temperature for PVC is 140° F. Valve pressure deratings at elevated temperatures apply.
  - **Safe-T-Blocked™ Seal Carrier**  
Blocked Seal Carrier allows safe removal of downstream union connection while valve is closed and under pressure. Fully adjustable to compensate for seat wear and for extended service life.
  - **Safe-T-Shear® Stem**  
This important safety feature was developed to prevent line fluids from leaking out in the event of accidental stem damage. Engineered for high strength, the stem incorporates a special shear point to control any breakage so that it is above the O-ring seal until repairs can be made.

## Technical Information

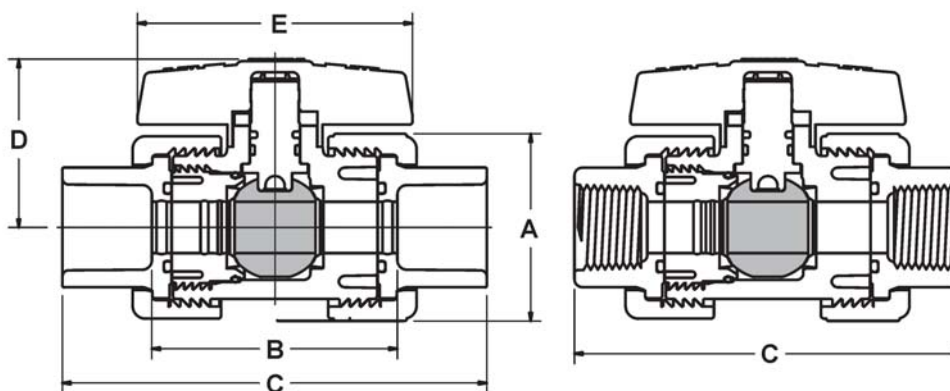

### Specifications in Inches

Size (inches)	A	B	C		D	E	Weight in Lbs.
			Socket	Threaded			
1/2	1-7/8	2-7/16	4-3/16	3-13/16	1-5/8	2-3/4	.35
3/4	2-1/4	2-3/4	4-3/4	4-1/4	2-1/16	3-1/4	.53
1	2-1/2	2-7/8	5-1/8	4-11/16	2-5/16	3-1/2	.77
1-1/4	3-1/16	3-1/4	5-3/4	5-3/16	2-11/16	3-3/4	1.15
1-1/2	3-1/2	3-1/2	6-1/4	5-7/16	3-1/16	4-1/4	1.47
2	4-1/4	4-3/4	7-3/4	6-3/4	3-3/4	5	2.33
3	6-3/16	7	10-11/16	9-3/4	5-7/8	7-5/8	7.46
4	7-3/4	7-1/2	11-7/8	10-1/4	6-3/4	9-1/16	12.35

### Specifications in Millimeters

Size (Millimeters)	A	B	C		D	E	Weight in Kilograms
			Socket	Threaded			
1/2	47.6	61.9	106.4	96.8	41.3	69.9	.158
3/4	57.2	69.9	120.7	108.0	52.7	82.6	.239
1	63.5	73.0	130.2	119.1	58.7	88.9	.347
1-1/4	77.8	82.6	146.1	131.8	68.3	95.3	.522
1-1/2	88.9	88.9	158.8	138.1	77.8	108.0	.666
2	108.0	120.7	196.9	171.5	95.3	127.0	1.055
3	157.2	177.8	271.5	247.7	149.2	193.7	3.380
4	196.9	190.5	301.6	260.4	171.5	230.2	5.600

### Part Numbers & C<sub>v</sub> Values

Size (inch)	Socket Part Number		Threaded Part Number		C <sub>v</sub> Values
1/2	EPDM	8822-005	EPDM	8821-005	29
	FKM	8832-005	FKM	8831-005	
3/4	EPDM	8822-007	EPDM	8821-007	63
	FKM	8832-007	FKM	8831-007	
1	EPDM	8822-010	EPDM	8821-010	120
	FKM	8832-010	FKM	8831-010	
1-1/4	EPDM	8822-012	EPDM	8821-012	243
	FKM	8832-012	FKM	8831-012	
1-1/2	EPDM	8822-015	EPDM	8821-015	357
	FKM	8832-015	FKM	8831-015	
2	EPDM	8822-020	EPDM	8821-020	599
	FKM	8832-020	FKM	8831-020	
3	EPDM	8822-030	EPDM	8821-030	1416
	FKM	8832-030	FKM	8831-030	
4	EPDM	8822-040	EPDM	8821-040	2865
	FKM	8832-040	FKM	8831-040	

### Sample Engineering Specifications

All thermoplastic ball valves shall be True Union Utility type constructed from NSF-61 approved PVC material, Type I, ASTM D 1784 Cell Classification 12454. All O-rings shall be EPDM or FKM. All valve seats shall be HDPE with PTFE or PTFE. All valves shall have Safe-T-Shear® stem with O-ring stem seal. All handles shall be polypropylene. All union nuts shall have Buttress threads. All seal carriers shall be Safe-T-Blocked®. All valves shall be PN16 pressure rated to 232 psi for water @ 73° F (22° C).



C<sub>v</sub> = US gallons per minute required to produce a 1 psi pressure drop.  
 Values calculated from derivative of Hazen-Williams formula with C=150  
 For valves with PTFE, add the letter "T" to the part number (e.g. 8822T-020).